

Kangaroo x2 Sample Wiring Diagram

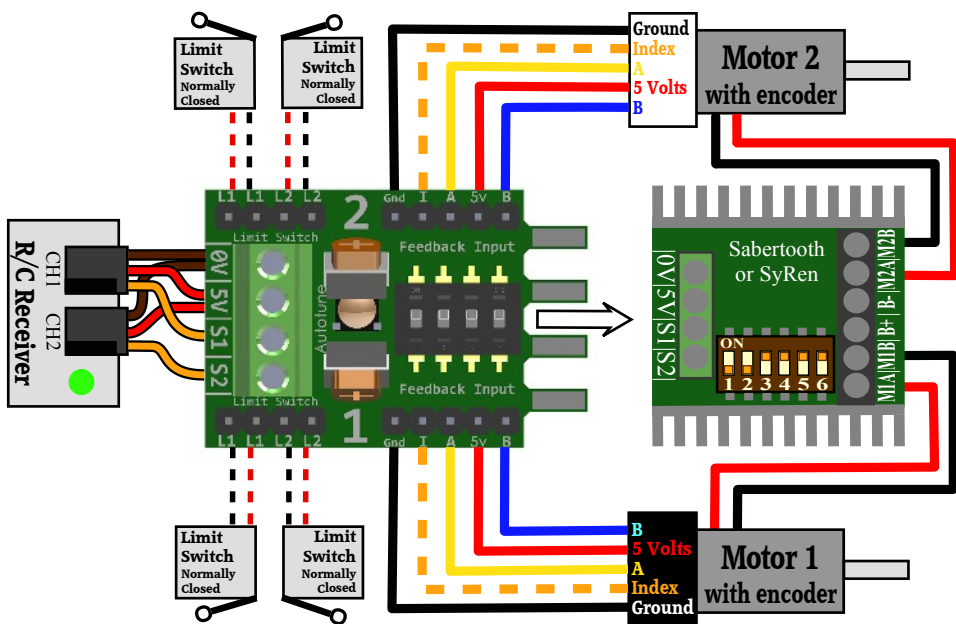

Operating mode DIP switch settings

1 OFF: Analog Input.

Connect 0-5V analog signals to the S1 and S2 inputs.

2 OFF: Analog Feedback

Connect a 0-5V signal to Feedback Input A

3 OFF: Velocity Control

Motor speed and direction are controlled by the input signal

4 OFF: Mixed Mode

The outputs are mixed together for differential drive

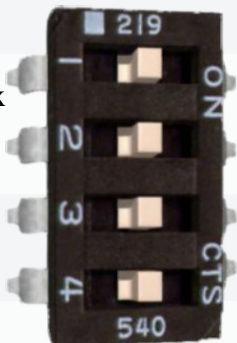

1 ON: Digital Input

R/C to S1 and S2 or connect serial TX to S1 and RX to S2

2 ON: Quadrature Feedback

Connect an encoder to Feedback Inputs A and B

3 ON: Position Control

Motor position is controlled by the input signal

4 on: Independent mode

The outputs are independent. S1 controls motor 1 and S2 motor 2

For the full manual, example videos, libraries, serial protocols and other documentation, please visit

www.dimensionengineering.com/kangaroo

Autotune

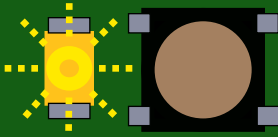

Tuning

Before being used, Kangaroo x2 must learn about the system. This is called tuning. Make sure everything is connected, then begin the appropriate tune sequence for your system.

Entering Tune mode

To enter tune mode, **press and hold the Autotune button for 2 seconds**. The yellow LED will begin to slowly flash one flash, followed by a pause. This indicates tune mode 1. To change to the next mode, press and hold the Autotune button for 2 seconds. **To accept the current tune mode and begin setup, click and release the Autotune button.** To cancel, remove power.

Mode 1 Teach	Mode 2 Limit Switches	Mode 3 Physical Stops
In this mode, an acceptable range of motion for tuning is taught by manually moving the device.	In this mode, normally closed limit switches are used to set the tuning and travel range.	In this mode, the device will gently move to physical stops at each end of the travel range.
With the LED flashing rapidly one blink, push each axis to one end of its travel range, then the other, then return it to the center. For rovers, push it a few feet each way, then back to center.	With the LED flashing rapidly two blinks and the limit switches connected, make sure each axis is near the center of its travel range.	With the LED flashing rapidly three blinks, make sure each axis is near the center of its travel range. Make sure the device is strong enough to stop the motor at slow speed at the ends of travel.
When you have finished the tune setup, click and release the Autotune button for a second time. GET CLEAR. In 10 seconds the device will begin to move automatically. When the tune cycle is finished and the device has stopped moving, if the tune succeeded the yellow LED will be on continuously. The settings are saved and the system is tuned. Remove and reconnect the power to use the device. If the light is blinking, the kangaroo encountered an error. See the manual for details.		

To calibrate the inputs, if necessary: Put both inputs into the neutral position, enter tune mode 4 then move each input to the maximum position, hold for 1 second, move to minimum position, hold for 1 second, then place it back into the neutral position. When finished, click the Autotune button a second time to save, and then re-power.

For the full manual, example videos, libraries, serial protocols and other documentation, please visit

www.dimensionengineering.com/kangaroo